



**MOTORI  
ASINCRONI  
TRIFASE  
NEMA**

(COSTRUZIONE IN GHISA)

***NEMA THREE-  
PHASE  
INDUCTION  
MOTORS***

(CAST-IRON CONSTRUCTION)



**ISGEV S.p.A.** progetta e costruisce motori elettrici fin dal 1948.

È presente sul mercato italiano e recentemente anche su quelli europei e americani, proponendo motori affidabili, di alta qualità.

La recente evoluzione tecnologica sia progettuale che produttiva e la rinnovata organizzazione aziendale conformata alle indicazioni delle norme ISO 9001:2000 sono garanzia di costante orientamento verso obiettivi di qualità e garanzia per il Cliente.



*ISGEV S.p.A. has been designing and constructing electric motors since 1948.*

*The company is present on the Italian market with its reliable, high-quality motors, which have been recently launched on the European and American markets as well.*

*The recent technological evolution in terms of both design and production, and the renewed company organization certified for conformity to ISO 9001:2000 Standards provide firm guarantees of the company's constant orientation towards the achievement of higher and higher quality objectives for assured performance and for the total satisfaction of the client.*

## Introduzione - Introduction

La IEC è un'organizzazione internazionale di cui fanno parte come membri 40 paesi, incluso l'USA e l'ITALIA, è nata con lo scopo di raggiungere un grado di standardizzazione mondiale per regolamentazione delle normative nel settore del campo elettrico. Se le raccomandazioni IEC non sono adottate, spetta comunque all'istituzione del paese membro a decidere a riguardo. I maggiori istituti in USA sono:

*The IEC is an international organisation with 40 member countries including the USA and ITALY. The IEC was established to attain a world-wide degree of standardisation to govern the norms in the electric field sector. In any case, if IEC recommendations are not adopted, the institution of the member country is responsible for making the relative decisions.*

*The major institutes in the USA are:*

<b>ANSI</b>	American National Standards Institute
<b>ASTMA</b>	American Society for Testing and Material.
<b>IEEE</b>	Institute of Electrical and Electronics Engineers.
<b>NEMA</b>	National Electrical Manufacturres Association.
<b>UL</b>	Underwriters Laboratories Incorporated.

**NEMA** è un'associazione nazionale il cui oggetto primario è facilitare la cooperazione tra produttori ed utenti di equipaggiamento elettrico. Tutti i maggiori produttori di attrezzature elettriche in USA sono membri di questa associazione. Come tutti altri standard nazionali, la pubblicazione NEMA è notevolmente più comprensivo delle raccomandazioni IEC. Il NEMA include le più importanti pubblicazioni per macchine elettriche:

*NEMA is a national association whose main objective is to facilitate co-operation between electric equipment manufacturers and users. All the major electric equipment manufacturers in the USA are members of this association. Like all other national standards, the NEMA publication is much more comprehensive than the IEC recommendations. NEMA includes the most important publications for electric machines:*

<b>MG1</b>	Motori e Generatori./Motors and Generators.
<b>MG2</b>	Standard di Sicurezza per Costruzione e Guida per Selezione Installazione ed Uso di Motori Elettrici./Construction Safety Standards and Guide for the Selection, Installation and Use of Electric Motors.
<b>MG3</b>	Livello del Suono per Macchine Elettriche./Sound Level for Electric Machines.
<b>MG10</b>	Guida per Selezione ed Uso dei Motori Elettrici./Guide for the Selection and Use of Electric Motors.
<b>MG13</b>	Correlazioni tra le potenze e le taglie dei Motori Elettrici./Power rating/size correlation for Electric Motors.

La pubblicazione MG1 può essere considerata una guida per il progetto dei motori standard richiesto per le costruzioni NEMA. Consiste dalle parti seguenti:

*The MG1 publication can be considered a standard motor design guide requested for NEMA construction configurations. It consists of the following parts:*

Part 1	Definizioni/Definitions
Part 2	Marcatura finale/Final marking
Part 3	Prova rigidità dielettrica/Dielectric strength test
Part 4	Dimensioni, tolleranze e tipi di costruzione/Dimensions, tolerances and construction types
Part 10	Potenze/Power ratings
Part 11	Dimensioni/Dimensions
Part 12	Collaudi/Tests
Part 14	Dati dell'applicazione/Application data
Part 15	Generatori DC/DC Generators
Part 16	Potenze motori e generatori sincroni/Motor and synchronous generators power ratings
Part 18	Definizioni/Definitions

I gradi di protezione (MG1-1.25), classi di isolamento (MG1-1.65) e i metodi di raffreddamento (MG1-1.25 e 1.26) NEMA sono comparabili con le raccomandazioni IEC.

*NEMA degrees of protection (MG1-1.25), insulation classes (MG1-1.65) and cooling methods (MG1-1.25 and 1.26) are comparable with the IEC recommendations.*

# MOTORI NEMA NEMA MOTORS

**COSTRUZIONE IN GHISA  
CAST-IRON CONSTRUCTION**



## **GARANZIA MOTORI ELETTRICI**

La I.S.G.E.V. S.p.A. garantisce la buona qualità e l'ottima costruzione di tutti i propri motori. Nel caso in cui si manifestino vizi dovuti a difetti di lavorazione o ad imperfetto montaggio, la I.S.G.E.V. si obbliga a riparare o sostituire gratuitamente le parti difettose nel più breve tempo possibile. Nei casi in cui il vizio sia dovuto a naturale logorio, imperizia del cliente o ad un utilizzo oltre i limiti delle prestazioni nominali e a manomissioni eseguite o fatte eseguire dal cliente, viene a decadere la garanzia. Il periodo di garanzia è di 12 mesi a partire dalla data di consegna ed in nessun caso, anche se il motore non è stato messo in servizio, i termini di garanzia potranno essere prorogati (articolo 1512 del codice civile). I lavori inerenti a riparazioni o sostituzioni durante il periodo di garanzia dovranno essere eseguiti presso i nostri stabilimenti. Il trasporto e il relativo costo sono a carico del cliente.



## **ELECTRIC MOTOR WARRANTY**

*I.S.G.E.V. S.p.A. guarantees the good quality and excellent construction of all its motors. If defects in workmanship or assembly should occur, I.S.G.E.V. will repair or replace the defective parts free of charge in the shortest possible time. The warranty will no longer be applicable for cases in which the defect is caused by natural wear and tear, customer inexperience, use beyond the limits of the rated performance or tampering by or requested by the customer. The 12-month warranty begins on the date of delivery and in no case can the warranty terms be extended, even if the motor was never placed in service (article 1512 of the civil code). The work relative to repairs or replacement during the warranty period must be carried out at our factory. The customer is responsible for arranging transport and paying for the relative costs.*

Forme costruttive NEMA, MG1-4.03.

NEMA construction forms, MG1-4.03.

I simboli usati nelle raccomandazioni IEC rappresentano le varie forme costruttive precedute dalle lettere "IM" (International Mounting), le relative simbologie NEMA sono rappresentate in tabella.

The symbols used in the IEC recommendations represent the various construction forms preceded by the letters "IM" (International Mounting). The relative NEMA symbols are represented in the table.

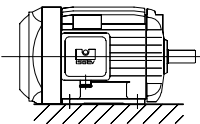
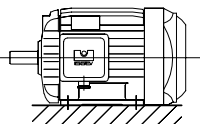
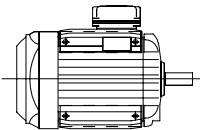
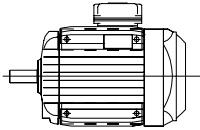
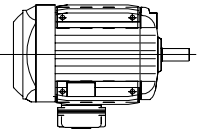
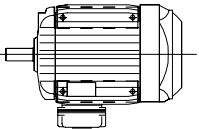
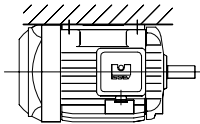
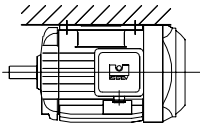
<p>FLOOR MOUNTINGS</p>				
<p>WALL MOUNTINGS</p>				
<p>CEILING MOUNTINGS</p>				
	<p>ASSEMBLY W - 1</p>	<p>ASSEMBLY W - 2</p>	<p>ASSEMBLY W - 3</p>	<p>ASSEMBLY W - 4</p>
	<p>ASSEMBLY W - 5</p>	<p>ASSEMBLY W - 6</p>	<p>ASSEMBLY W - 7</p>	<p>ASSEMBLY W - 8</p>
	<p>ASSEMBLY C - 1</p>		<p>ASSEMBLY C - 2</p>	

Le forme costruttive vengono distinte in tre gruppi principali:  
*The construction forms are divided into three main groups:*

- F) montaggio a pavimento/floor mounted
- W) montaggio a parete/wall mounted
- C) montaggio a soffitto/ceiling mounted

## Collegamenti

La scatola morsettiera presenta nella versione standard grado di protezione IP55, su richiesta è realizzata con grado IP56. Per tutte le altezze d'asse la scatola morsettiera può essere ruotata di 90° in 90° e posta a Dx o Sx rispetto all'asse motore. Per l'uscita sono previsti raccordi NPT e, affinché la scatola morsettiera possa mantenere le caratteristiche di tenuta, si consiglia di impiegare cavi di dimensioni adeguate. Il numero di raccordi e le dimensioni degli stessi sono riportati nella tabella.

NEMA FRAME	N°	RACCORDO NIPPLES
143 - 184	1	NPT 1/2"
213 - 215	1	NPT 3/4"
254 - 286	1	NPT 1"
324 - 326	1	NPT 1-1/2"
364 - 405	1	NPT 2"

## Connections

The standard terminal box with degree of protection IP55 can be built on request with degree IP56. For all axis heights, the terminal box can be rotated by multiples of 90° and installed Right or Left with respect to the motor axis. NPT connectors are utilised for the output and it is recommended to use cables with adequate dimensions, so that the terminal box can maintain its sealing characteristics. The number of connectors and their dimensions are indicated in the table.

## Cuscinetti

Per tutte le altezze d'asse sono previsti cuscinetti a sfera lubrificati a grasso, le dimensioni dei cuscinetti impiegati sono riportate in tabella. Di norma il cuscinetto opposto al lato accoppiamento è montato con anello di compensazione per ridurre al minimo i giochi ed eventuali vibrazioni. Su richiesta vengono montati cuscinetti 2RS oppure con gioco C3. E' disponibile inoltre una vasta gamma di soluzioni con cuscinetti maggiorati e sistemi di lubrificazione.

## Bearings

Grease-lubricated ball bearings are utilised for all axis heights. The dimensions of the bearings used are indicated in the table. The bearing opposite the coupling side is usually mounted with a compensation ring to reduce clearance and vibrations to a minimum. On request, 2RS or C3 clearance bearings can also be mounted. A wide range of solutions with oversized bearings and lubrication systems is also available.

TABELLA CUSCINETTI - TABLE BEARINGS

MOTORE TIPO MOTOR TYPE	CUSCINETTO LATO ACCOPPIAMENTO COUPLING SIDE BEARING		CUSCINETTO LATO OPPOSTO OPPOSITE SIDE BEARING
143 - 145	6205 2Z		6205 2Z
182 - 184	6306 2Z	*NU 306	6306 2Z
213 - 215	6308 2Z	*NU 308	6308 2Z
254 - 256	6310 2Z	*NU 310	6310 2Z
284 - 286	6311	*NU 311	6311
324 - 326	6312	*NU 312	6312
364 - 365 - 2poli / 2poles 364 - 365 - 4poli / 4poles	6214 NU 214		6214 6214
404 - 405 - 2poli / 2poles 404 - 405 - 4poli / 4poles	6314 C3 6314 C3	*NU 314	6314 C3 6314 C3

\* Cuscinetti a rulli su richiesta. - Roller bearing available on request.

**2 POLI/POLES**

 2 POLI 3600 rpm Caratteristiche a Volt 460 Hz 60  
 2 POLES 3600 rpm Characteristics a Volt 460 Hz 60

MODELLO TYPE	POTENZA POWER [HP]	VELOCITÀ SPEED [min <sup>-1</sup> ]	RENDIMENTO EFFICIENCY 100%	F. di P. P. F. Cosφ	CORRENTE CURRENT		COPPIA TORQUE			MOMENTO di INERZIA MOMENT of INERTIA kgm <sup>2</sup>
					In [A]	Is/In	Tn [Nm]	Ts/Tn	Tmax/Tn	
143	1,5	3380	76	0,82	2,26	5,3	3,1	2,7	2,7	0,0009
145	2	3410	80	0,83	2,85	5,9	4,2	2,5	2,7	0,0016
184*	3	3410	80	0,83	4,2	5,5	6,2	2,5	2,6	0,0021
184	5	3490	85	0,85	6,3	8,5	9,9	2,8	3,6	0,00625
213	7,5	3480	85	0,87	9,3	7	15,1	2,6	3,3	0,01075
215	10	3480	86	0,86	12,7	7,7	20,6	2,5	3,4	0,01175
254	15	3490	86	0,86	18,7	7,6	30,1	2,5	3,6	0,023
256	20	3500	87	0,87	24,9	7,5	41	2,5	3,6	0,0275
284	25	3490	86	0,87	31,1	8,3	50,6	3	3,4	0,035
286	30	3540	90	0,88	35	7,6	59,4	2,4	3,1	0,095
324	40	3530	89	0,9	47	9	81,2	3,3	3,6	0,135
326	50	3540	90,6	0,89	57,7	8,5	99,9	3,3	3,6	0,1625
364	60	3560	90,5	0,9	69,4	8	120,8	2,7	2,7	0,2425
365	75	3560	91	0,88	86,3	7,5	147,6	2,5	2,3	0,4125
405	100	3560	92	0,88	116	7,4	201	2,4	2,1	0,55

**4 POLI/POLES**

 4 POLI 1800 rpm Caratteristiche a Volt 460 Hz 60  
 4 POLES 1800 rpm Characteristics a Volt 460 Hz 60

MODELLO TYPE	POTENZA POWER [HP]	VELOCITÀ SPEED [min <sup>-1</sup> ]	RENDIMENTO EFFICIENCY 100%	F. di P. P. F. Cosφ	CORRENTE CURRENT		COPPIA TORQUE			MOMENTO di INERZIA MOMENT of INERTIA kgm <sup>2</sup>
					In [A]	Is/In	Tn [Nm]	Ts/Tn	Tmax/Tn	
143	1,0	1680	74	0,78	1,63	4,9	4,3	2,1	2,1	0,001725
145	1,5	1696	79	0,78	2,24	4,9	6,2	2,2	2,4	0,00275
145	2	1700	81	0,78	3	4,3	8,4	2,2	2,4	0,0035
184*	3	1710	81	0,82	4,2	5,9	12,3	2,2	2,6	0,00925
184	5	1730	84	0,86	6,5	7,3	20,5	3,1	3,3	0,0185
213	7,5	1730	85	0,85	9,6	6	30,4	2,5	2,9	0,0275
215	10	1740	87	0,85	12,7	6,1	41,2	2,7	3	0,0325
254	15	1740	87	0,85	18,7	7,4	60,4	2,5	2,9	0,06
256	20	1730	87	0,87	24,9	7	83	2,7	3,1	0,075
284	25	1730	89	0,87	30	7,3	102	2,5	3,3	0,16
286	30	1730	90	0,87	35,3	7,5	122	3,3	3,3	0,1925
324	40	1740	91	0,87	47,6	7,5	165	2,3	2,9	0,24
326	50	1760	91	0,88	58	6	201	1,9	2,4	0,425
364	60	1765	92	0,88	70	6,4	244	1,9	2,6	0,475
365	75	1775	93,5	0,88	84	7,3	296	2,4	3	0,675
405	100	1775	92	0,86	119	6	404	1,6	2,7	0,725

## 6 POLI/POLES

6 POLI 1200 rpm Caratteristiche a Volt 460 Hz 60  
6 POLES 1200 rpm Characteristics a Volt 460 Hz 60

MODELLO TYPE	POTENZA POWER [HP]	VELOCITÀ SPEED [min <sup>-1</sup> ]	RENDIMENTO EFFICIENCY 100%	F. di P. P. F. Cosφ	CORRENTE CURRENT		COPPIA TORQUE			MOMENTO di INERZIA MOMENT of INERTIA kgm <sup>2</sup>
					In [A]	Is/In	Tn [Nm]	Ts/Tn	Tmax/Tn	
143	0,75	1135	68	0,74	1,37	1,9	4,6	1,9	2,1	0,003
145	1	1130	71	0,73	1,82	3,2	6,3	1,9	2	0,00475
182	1,5	1130	74	0,74	2,5	3,4	9,3	1,9	2	0,00625
184	2	1115	76	0,78	3,2	3,9	12,8	1,9	2,1	0,011
213	3	1135	79	0,78	4,5	4,7	18,5	2	2,4	0,02125
215	5	1190	83	0,78	7,2	5,7	30,7	2,7	2,6	0,04
254	7,5	1150	84	0,8	10,3	4,7	45,7	2,1	2,4	0,05
256	10	1160	88	0,78	13,7	6,2	61,8	2,3	3,2	0,0875
284	15	1145	88	0,79	19,9	5,5	91,8	2,2	2,9	0,11
286	20	1160	88	0,83	25,8	5,7	123,5	2	2,7	0,2575
324	25	1165	91	0,84	30,4	5,7	152	1,8	2,4	0,375
326	30	1165	91	0,84	36,2	5,7	180	1,8	2,5	0,45
364	40	1165	91	0,81	51	6	246	2	2,5	0,675
365	50	1170	91,5	0,81	63	5,7	302	2	2,5	0,925
404	60	1175	94	0,8	75	6,5	366	2,4	2,7	0,925
405	75	1180	94	0,8	92	6,7	445	2,1	2,6	1,075

## 8 POLI/POLES

8 POLI 900 rpm Caratteristiche a Volt 460 Hz 60  
8 POLES 900 rpm Characteristics a Volt 460 Hz 60

MODELLO TYPE	POTENZA POWER [HP]	VELOCITÀ SPEED [min <sup>-1</sup> ]	RENDIMENTO EFFICIENCY 100%	F. di P. P. F. Cosφ	CORRENTE CURRENT		COPPIA TORQUE			MOMENTO di INERZIA MOMENT of INERTIA kgm <sup>2</sup>
					In [A]	Is/In	Tn [Nm]	Ts/Tn	Tmax/Tn	
143	0,5	840	60	0,65	1,2	2,9	4,2	1,8	2,1	0,00475
145	0,75	840	65	0,66	1,6	3	6,2	1,7	1,8	0,00625
182	1	840	72	0,64	2	3,9	8,5	2,4	2,3	0,011
184	1,5	840	72	0,7	2,7	3,8	12,5	2	2,1	0,01425
213	2	845	76	0,72	3,4	3,6	17	1,7	2	0,0235
215	3	845	77	0,73	4,9	3,8	24,9	1,6	2	0,03775
254	5	860	81	0,73	7,9	5,7	41,1	2,7	3	0,09125
256	7,5	850	83	0,76	11	5,3	61,8	2,5	2,7	0,1125
284	10	850	84	0,77	14,6	5,7	84,3	2,4	2,7	0,14
286	15	835	83	0,82	20,3	4,5	126	2,2	2,1	0,2575
324	20	865	87	0,83	26,1	5	166	1,8	2,1	0,375
326	25	865	88	0,84	31,4	4,7	204	2	2,2	0,725
364	30	865	89	0,84	37	4,8	243	2,1	2,4	0,85
365	40	870	90	0,84	49,9	4,5	329	1,8	2	1,025
404	50	875	91	0,85	40	5	404	1,7	1,9	1,125
405	60	875	91	0,85	73	5	491	1,7	1,9	1,375

Conformità dimensioni motori NEMA con lo standard IEC  
NEMA motor size conformity to IEC standards

HP	2p. 3600		4p. 1800		6p. 1200		8p. 900	
0,5			56	80			143	90 S
0,75					143	90 S	145	90 L
1			143	90 S	145	90 L	182	112 M
1,5	143	90 S	145	90 L	182	112 M	184	112 M
2	145	90 L	145	90 L	184	112 M	213	132 S
3	182	112 M	182	112 M	213	132 S	215	132 M
5	184	112 M	184	112 M	215	132 M	254	160 M
7,5	213	132 S	213	132 S	254	160 M	256	160 L
10	215	132 M	215	132 M	256	160 L	284	180 M
15	254	160 M	254	160 M	284	180 M	286	180 L
20	256	160 L	256	160 L	286	180 L	324	200 L
25	284	180 M	284	180 M	324	200 L	326	200 L
30	286	180 L	286	180 L	326	200 L	364	225 S
40	324	200 L	324	200 L	364	225 S	365	225 M
50	326	200 L	326	200 L	365	225 M	404	250 M
60	364	225 S	364	225 S	404	250 M	405	250 M
75	365	225 M	365	225 M	405	250 M	444	280 S
100	405	250 M	405	250 M				
125	444	280 S	444	280 S				

FRAME		FORME COSTRUTTIVE - CONSTRUCTION FORMS				
IEC	NEMA	T (B3)	D (B5)	C (B14)	TD (B35)	TC (B34)
90 S	143	○	○	○	○	○
90 L	145	○	○	○	○	○
112 M (S)	182	□	○	○	□	□
112 M	184	○	○	○	○	○
132 S	213	○	○	○	○	○
132 M	215	○	○	○	○	○
160 M	254	○	○	▲	○	○
160 L	256	○	○	▲	○	○
180 M	284	○	○	▲	○	▲
180 L	286	○	○	▲	○	▲
200 L (S)	324	□	○	□	□	□
200 L	326	○	○	▲	○	▲
225 M (S)	364	○	▲	▲	▲	▲
225 M	365	○	▲	▲	▲	▲
250 M (S)	404	▲	○	▲	▲	▲
250 M	405	○	○	▲	○	▲
280 S	444	▲	▲	▲	▲	▲
280 M	445	▲	▲	▲	▲	▲

○ STANDARD

□ NON REGOLARE  
NON-STANDARD

▲ NON DISPONIBILE AL MOMENTO  
NOW NOT AVAILABLE

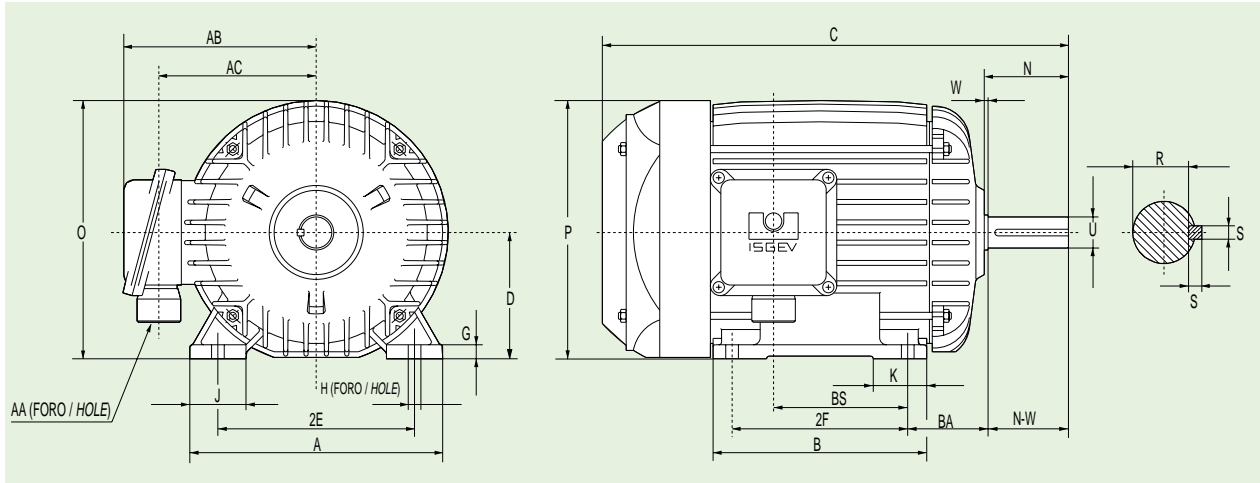

Tolleranza quota D: Da 0 a -0.76  
Tolleranza quota U: Fino al  $\varnothing$  34.925 da 0 a -0.013, oltre, da 0 a -0.025  
Da frame 213T (AS 132S) con golfare di sollevamento

D dimension tolerance: 0 to -0.76  
U dimension tolerance: up to  $\varnothing$  34.925 from 0 to -0.013, over, from 0 to -0.025  
From frame 213T (AS 132S) with lifting eyebolt

Forma costruttiva con piedini (NEMA T)  
Construction form with feet (NEMA T)

Dimensioni in millimetri - Dimensions in millimeters

NEMA Frame Number	ISGEV Tipo Type	ACCOPPIAMENTO - SPORGENZA ALBERO (NEMA) COUPLING - SHAFT PROJECTION									INGOMBRO OVERALL DIMENSIONS													
		D	2E	2F	BA	H	U	N-W	R	S	A	B	J	K	G	C	BS	N	W	O	P	AB	AC	AA NPT
143 T	AS 90 S	88.9	139.7	101.6	57.2	8.8	22.225	57.2	19.58	4.77	180	127	40	38	9	307	70.5	59.9	2.7	184	189	140	112	1/2"
145 T	AS 90 L	88.9	139.7	127.0	57.2	8.8	22.225	57.2	19.58	4.77	180	152	40	38	9	332	95.5	59.9	2.7	184	189	140	112	1/2"
182 T	AS 112 S																							
184 T	AS 112 M	114.3	190.5	139.7	69.9	10.4	28.575	69.9	25.04	6.35	228	184	52	50	13	398	105.1	73.8	3.9	234	239	179	143	1/2"
213 T	AS 132 S	133.4	215.9	139.7	88.9	10.4	34.925	85.7	30.50	7.92	260	198	60	58	14	454	102.1	90.6	4.9	270	268	204	162	3/4"
215 T	AS 132 M	133.4	215.9	177.8	88.9	10.4	34.925	85.7	30.50	7.92	260	236	60	58	14	492	140.1	90.6	4.9	270	268	204	162	3/4"
254 T	AS 160 M	158.8	254.0	209.6	108.0	13.5	41.275	101.6	35.96	9.52	310	272	65	70	17	588	162.0	111.6	10.0	326	324	245	194	1"
256 T	AS 160 L	158.8	254.0	254.0	108.0	13.5	41.275	101.6	35.96	9.52	310	316	65	70	17	632	206.0	111.6	10.0	326	324	245	194	1"
284 T	AS 180 M	177.8	279.4	241.3	120.7	13.5	47.625	117.5	40.41	12.70	350	308	70	75	22	671	195.8	120.5	3	368	365	265	214	1"
284 TS	AS 180 M	177.8	279.4	241.3	120.7	13.5	41.275	82.6	35.96	9.52	350	308	70	75	22	636	195.8	85.6	3	368	365	265	214	1"
286 T	AS 180 L	177.8	279.4	279.4	120.7	13.5	47.625	117.5	40.41	12.70	350	346	70	75	22	709	233.8	120.5	3	368	365	265	214	1"
286 TS	AS 180 L	177.8	279.4	279.4	120.7	13.5	41.275	82.6	35.96	9.52	350	346	70	75	22	674	233.8	85.6	3	368	365	265	214	1"
324 T	AS 200 M	203.2	317.5	266.7	133.4	16.7	53.975	133.4	46.86	12.70	396	370	78	85	31	786	256.1	142.3	8.9	412	407	317	254	1-1/2"
324 TS	AS 200 M	203.2	317.5	266.7	133.4	16.7	47.625	95.3	40.41	12.70	396	370	78	85	31	748	256.1	104.2	8.9	412	407	317	254	1-1/2"
326 T	AS 200 L	203.2	317.5	304.8	133.4	16.7	53.975	133.4	46.86	12.70	396	370	78	85	31	786	256.1	142.3	8.9	412	407	317	254	1-1/2"
326 TS	AS 200 L	203.2	317.5	304.8	133.4	16.7	47.625	95.3	40.41	12.70	396	370	78	85	31	748	256.1	104.2	8.9	412	407	317	254	1-1/2"
364 T	AS 225 S	228.6	355.6	285.8	149.3	16.7	60.325	149.2	51.33	15.87	440	380	85	95	35	838	249.0	154.2	5.2	457	447	392	288	2"
364 TS	AS 225 S	228.6	355.6	285.8	149.3	16.7	47.625	95.3	40.41	12.70	440	380	85	95	35	784	249.0	100.5	5.2	457	447	392	288	2"
365 T	AS 225 M	228.6	355.6	311.2	149.3	16.7	60.325	149.2	51.33	15.87	440	380	85	95	35	838	249.0	154.2	5.2	457	447	392	288	2"
365 TS	AS 225 M	228.6	355.6	311.2	149.3	16.7	47.625	95.3	40.41	12.70	440	380	85	95	35	784	249.0	100.5	5.2	457	447	392	288	2"
404 T	BS 250 S	254.0	406.4	311.2	168.3	20.7	73.025	184.2	62.23	19.05	500	410	102	87	39	991	87	188.2	4.0	509	510	395	325	2"
404 TS	BS 250 S	254.0	406.4	311.2	168.3	20.7	53.975	108.0	46.86	12.70	500	410	102	87	39	914	87	112.0	4.0	509	510	395	325	2"
405 T	BS 250 M	254.0	406.4	349.3	168.3	20.7	73.025	184.2	62.23	19.05	500	410	102	87	39	991	87	188.2	4.0	509	510	395	325	2"
405 TS	BS 250 M	254.0	406.4	349.3	168.3	20.7	53.975	108.0	46.86	12.70	500	410	102	87	39	914	87	112.0	4.0	509	510	395	325	2"

Dati non impegnativi - con riserva di apportare modifiche / These data are not legally binding. The Manufacturer reserves the right to modify its products without notice.

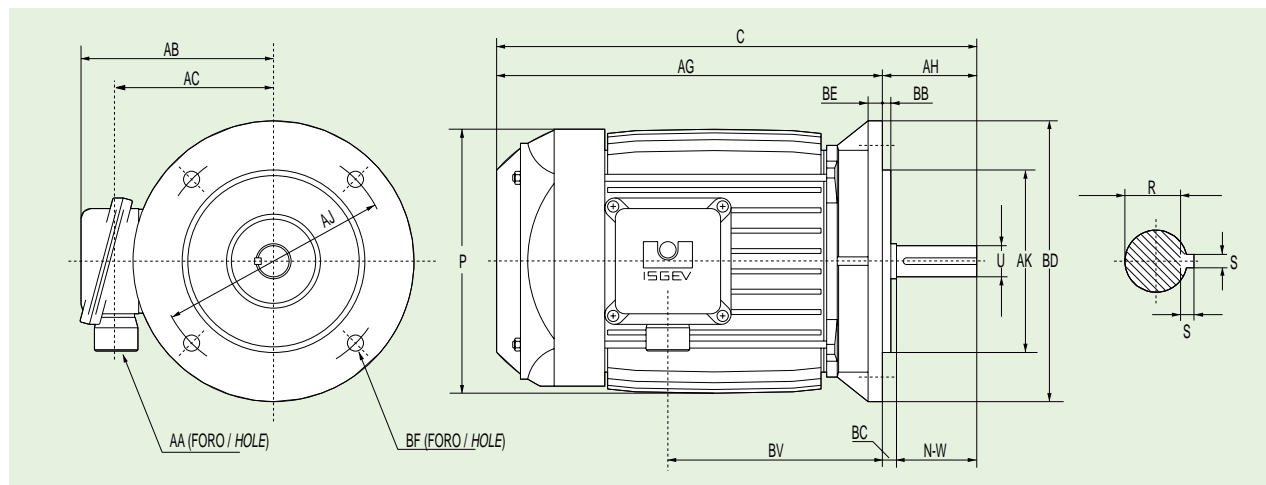

Tolleranza quota U: Fino al  $\varnothing$  34.925 da 0 a -0.013 , oltre, da 0 a -0.025  
 Tolleranza quota AK: Fino a frame 286D (AS 180L) da 0 a -0.076 , oltre, da 0 a -0.127  
 Tolleranza quota BB: da 0 a -1.5  
 Da frame 213D (AS 132S) con golfare di sollevamento  
 Da frame 404D (BS 250) flangia con 8 fori

U dimension tolerance: up to  $\varnothing$  34.925 from 0 to -0.013, over, from 0 to -0.025  
 AK dimension tolerance: up to frame 286D (AS180L) from 0 to -0.076, over, from 0 to -0.127  
 BB dimension tolerance: 0 to -1.5  
 From frame 213D (AS 132S) with lifting eyebolt  
 From 404D (BS 250) flange with 8 holes

Forma costruttiva con flangia a fori passanti (NEMA D)  
 Construction form with flange with through holes (NEMA D)

Dimensioni in millimetri - Dimensions in millimeters

NEMA Frame Number	ISGEV Tipo Type	ACCOPIAMENTO - SPORGENZA ALBERO COUPLING - SHAFT PROJECTION (NEMA)										INGOMBRO OVERALL DIMENSIONS							
		BD MAX	AJ	AK	BB	BC	BF	U	AH N-W	R	S	BE	C	AG	P	AB	AC	BV	AA NPT
143 D	AS 90 S	279.4	254	228.6	6.3	0	13.5	22.225	57.2	19.58	4.77	10	307	249.8	189	140	112	123.7	1/2"
145 D	AS 90 L	279.4	254	228.6	6.3	0	13.5	22.225	57.2	19.58	4.77	10	332	274.8	189	140	112	148.7	1/2"
182 D	AS 112 S	279.4	254	228.6	6.3	0	13.5	28.575	69.9	25.04	6.35	12.8	417	347.1	239	179	143	193.8	1/2"
184 D	AS 112 M	279.4	254	228.6	6.3	0	13.5	28.575	69.9	25.04	6.35	12.8	417	347.1	239	179	143	193.8	1/2"
213 D	AS 132 S	279.4	254	228.6	6.3	0	13.5	34.925	85.7	30.50	7.92	12	454	368.3	268	204	162	191.0	3/4"
215 D	AS 132 M	279.4	254	228.6	6.3	0	13.5	34.925	85.7	30.50	7.92	12	492	406.3	268	204	162	229.0	3/4"
254 D	AS 160 M	355.6	317.5	279.4	6.3	0	20.7	41.275	101.6	35.96	9.52	15	588	486.4	324	245	194	270.0	1"
256 D	AS 160 L	355.6	317.5	279.4	6.3	0	20.7	41.275	101.6	35.96	9.52	15	632	530.4	324	245	194	314.0	1"
284 D	AS 180 M	355.6	317.5	279.4	6.3	0	20.7	47.625	117.5	40.41	12.70	15	671	553.5	365	265	214	316.5	1"
284 SD	AS 180 M	355.6	317.5	279.4	6.3	0	20.7	41.275	82.6	35.96	9.52	15	636	553.5	365	265	214	316.5	1"
286 D	AS 180 L	355.6	317.5	279.4	6.3	0	20.7	47.625	117.5	40.41	12.70	15	709	591.5	365	265	214	354.5	1"
286 SD	AS 180 L	355.6	317.5	279.4	6.3	0	20.7	41.275	82.6	35.96	9.52	15	674	591.5	365	265	214	354.5	1"
324 D	AS 200 M	457.2	406.4	355.6	6.3	0	20.7	53.975	133.4	46.86	12.70	18	787	653.6	407	317	254	389.5	1-1/2"
324 SD	AS 200 M	457.2	406.4	355.6	6.3	0	20.7	47.625	95.3	40.41	12.70	18	749	653.6	407	317	254	389.5	1-1/2"
326 D	AS 200 L	457.2	406.4	355.6	6.3	0	20.7	53.975	133.4	46.86	12.70	18	787	653.6	407	317	254	389.5	1-1/2"
326 SD	AS 200 L	457.2	406.4	355.6	6.3	0	20.7	47.625	95.3	40.41	12.70	18	749	653.6	407	317	254	389.5	1-1/2"
364 D	AS 225 S	457.2	406.4	355.6	6.3	0	20.7	60.325	149.2	51.33	15.87	20.3	838	688.8	447	392	288	398.3	2"
364 SD	AS 225 S	457.2	406.4	355.6	6.3	0	20.7	47.625	95.3	40.41	12.70	20.3	784	688.8	447	392	288	398.3	2"
365 D	AS 225 M	457.2	406.4	355.6	6.3	0	20.7	60.325	149.2	51.33	15.87	20.3	838	688.8	447	392	288	398.3	2"
365 SD	AS 225 M	457.2	406.4	355.6	6.3	0	20.7	47.625	95.3	40.41	12.70	20.3	784	688.8	447	392	288	398.3	2"
404 D	BS 250 S	558.8	508	457.2	6.3	0	20.7	73.025	184.2	62.23	19.05	20	991	806.8	510	395	325	255.3	2"
404 SD	BS 250 S	558.8	508	457.2	6.3	0	20.7	53.975	108.0	46.86	12.70	20	914	806.8	510	395	325	255.3	2"
405 D	BS 250 M	558.8	508	457.2	6.3	0	20.7	73.025	184.2	62.23	19.05	20	991	806.8	510	395	325	255.3	2"
405 SD	BS 250 M	558.8	508	457.2	6.3	0	20.7	53.975	108.0	46.86	12.70	20	914	806.8	510	395	325	255.3	2"

Dati non impegnativi - con riserva di apportare modifiche / These data are not legally binding. The Manufacturer reserves the right to modify its products without notice.

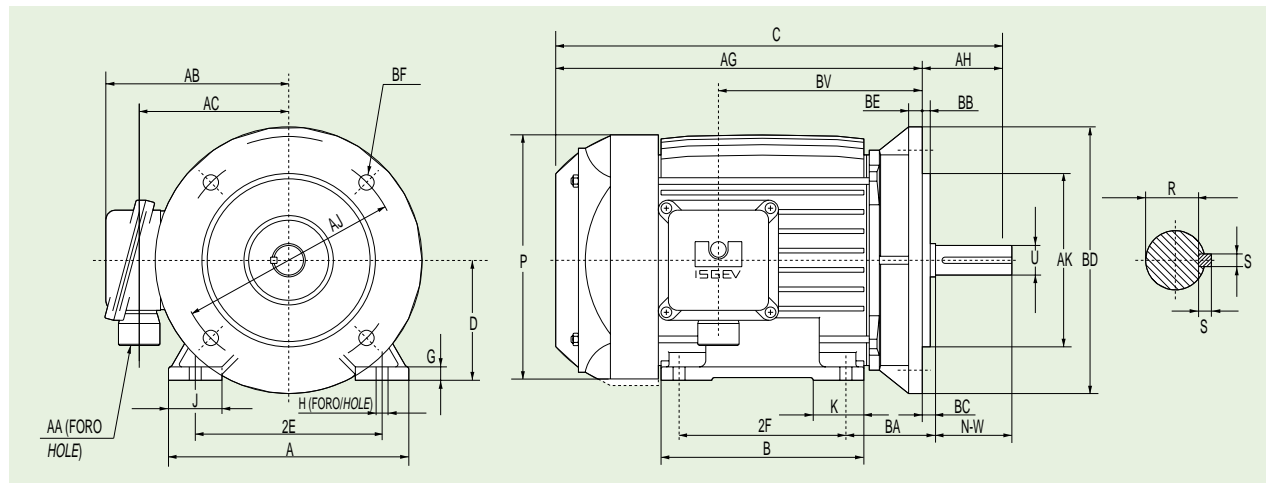

Tolleranza quota D: Da 0 a -0.76  
 Tolleranza quota U: Fino al ø 34.925 da 0 a -0.013 oltre, da 0 a -0.025  
 Tolleranza quota AK: Fino a frame 286TD (AS 180L) da 0 a -0.076, oltre, da 0 a -0.127  
 Tolleranza quota BB: da 0 a -1.5  
 Da frame 213TD (AS 132S) con golfare di sollevamento  
 Da frame 404TD (BS 250M) flangia con 8 fori

D dimension tolerance: 0 to -0.76  
 U dimension tolerance: up to ø 34.925 from 0 to -0.013, over, from 0 to -0.025  
 AK dimension tolerance: up to frame 286TSD(AS180L) from 0 to -0.076, over from 0 to -0.127  
 From frame 213TD (AS 132S) with lifting eyebolt  
 From 404TD (BS 250M) flange with 8 holes

Forma costruttiva con piedini e flangia a fori passanti (NEMA TD)  
 Construction form with feet and flange with through holes (NEMA TD)

**Dimensioni in millimetri - Dimensions in millimeters**

NEMA Frame Number	ISGEV Tipo Type	ACCOPIAMENTO - SPORGENZA ALBERO (NEMA) COUPLING - SHAFT PROJECTION														INGOMBRO OVERALL DIMENSIONS													
		D	2E	2F	BA	H	BD max	AJ	AK	BB	BC	BF	U	AH N-W	R	S	A	B	J	K	G	C	AG	P	AB	AC	BV	BE	AA NPT
143 TD	AS 90 S	88.9	139.7	101.6	69.9	8.8	279.4	254	228.6	6.3	0	13.5	22.225	57.2	19.58	4.77	180	127	40	38	9	319	261.8	189	140	112	140.4	12.7	1/2"
145 TD	AS 90 M	88.9	139.7	127.0	69.9	8.8	279.4	254	228.6	6.3	0	13.5	22.225	57.2	19.58	4.77	180	152	40	38	9	344	286.8	189	140	112	165.4	12.7	1/2"
182 TD	AS 112 S																												
184 TD	AS 112 M	114.3	190.5	139.7	88.9	10.4	279.4	254	228.6	6.3	0	13.5	28.575	69.9	25.04	6.35	228	184	52	50	13	417	347.1	239	179	143	193.8	12.7	1/2"
213 TD	AS 132 S	133.4	215.9	139.7	108.0	10.4	279.4	254	228.6	6.3	0	13.5	34.925	85.7	30.50	7.92	260	198	60	58	14	473	387.3	268	204	162	210.0	12.7	3/4"
215 TD	AS 132 M	133.4	215.9	177.8	108.0	10.4	279.4	254	228.6	6.3	0	13.5	34.925	85.7	30.50	7.92	260	236	60	58	14	511	425.3	268	204	162	248.0	12.7	3/4"
254 TD	AS 160 M	158.8	254.0	209.6	120.7	13.5	355.6	317.5	279.4	6.3	0	20.7	41.275	101.6	35.96	9.52	310	272	65	70	17	601	499.4	324	245	194	282.7	12.7	1"
256 TD	AS 160 L	158.8	254.0	254.0	120.7	13.5	355.6	317.5	279.4	6.3	0	20.7	41.275	101.6	35.96	9.52	310	316	65	70	17	645	543.4	324	245	194	326.7	12.7	1"
284 TD	AS 180 M	177.8	279.4	241.3	120.7	13.5	355.6	317.5	279.4	6.3	0	20.7	47.625	117.5	40.41	12.70	350	308	70	75	22	671	553.5	365	265	214	316.5	15	1"
284TSD	AS 180 M	177.8	279.4	241.3	120.7	13.5	355.6	317.5	279.4	6.3	0	20.7	41.275	82.6	35.96	9.52	350	308	70	75	22	636	553.5	365	265	214	316.5	15	1"
286 TD	AS 180 L	177.8	279.4	279.4	120.7	13.5	355.6	317.5	279.4	6.3	0	20.7	47.625	117.5	40.41	12.70	350	346	70	75	22	709	591.5	365	265	214	354.5	15	1"
286TSD	AS 180 L	177.8	279.4	279.4	120.7	13.5	355.6	317.5	279.4	6.3	0	20.7	41.275	82.6	35.96	9.52	350	346	70	75	22	674	591.5	365	265	214	354.5	15	1"
324 TD	AS 200 M	203.2	317.5	266.7	133.4	16.7	457.2	406.4	355.6	6.3	0	20.7	53.975	133.4	46.86	12.70	396	370	78	85	31	787	653.6	407	317	254	389.5	18	1-1/2"
324TSD	AS 200 M	203.2	317.5	266.7	133.4	16.7	457.2	406.4	355.6	6.3	0	20.7	47.625	95.3	40.41	12.70	396	370	78	85	31	749	653.6	407	317	254	389.5	18	1-1/2"
326 TD	AS 200 L	203.2	317.5	304.8	133.4	16.7	457.2	406.4	355.6	6.3	0	20.7	53.975	133.4	46.86	12.70	396	370	78	85	31	787	653.6	407	317	254	389.5	18	1-1/2"
326TSD	AS 200 L	203.2	317.5	304.8	133.4	16.7	457.2	406.4	355.6	6.3	0	20.7	47.625	95.3	40.41	12.70	396	370	78	85	31	749	653.6	407	317	254	389.5	18	1-1/2"
364 TD	AS 225 S	228.6	355.6	285.8	149.3	16.7	457.2	406.4	355.6	6.3	0	20.7	60.325	149.2	51.33	15.87	440	380	85	95	35	838	688.8	447	392	288	404.6	20.3	2"
364TSD	AS 225 S	228.6	355.6	285.8	149.3	16.7	457.2	406.4	355.6	6.3	0	20.7	47.625	95.3	40.41	12.70	440	380	85	95	35	784	688.8	447	392	288	404.6	20.3	2"
365 TD	AS 225 M	228.6	355.6	311.2	149.3	16.7	457.2	406.4	355.6	6.3	0	20.7	60.325	149.2	51.33	15.87	440	380	85	95	35	838	688.8	447	392	288	404.6	20.3	2"
365TSD	AS 225 M	228.6	355.6	311.2	149.3	16.7	457.2	406.4	355.6	6.3	0	20.7	47.625	95.3	40.41	12.70	440	380	85	95	35	784	688.8	447	392	288	404.6	20.3	2"
404 TD	BS 250 S	254.0	406.4	311.2	168.3	20.7	558.8	508	457.2	6.3	0	20.7	73.025	184.2	62.23	19.05	500	410	102	87	39	991	806.8	510	395	325	255.3	20	2"
404TSD	BS 250 S	254.0	406.4	311.2	168.3	20.7	558.8	508	457.2	6.3	0	20.7	53.975	108.0	46.86	12.70	500	410	102	87	39	914	806.8	510	395	325	255.3	20	2"
405 TD	BS 250 S	254.0	406.4	349.3	168.3	20.7	558.8	508	457.2	6.3	0	20.7	73.025	184.2	62.23	19.05	500	410	102	87	39	991	806.8	510	395	325	255.3	20	2"
405TSD	BS 250 S	254.0	406.4	349.3	168.3	20.7	558.8	508	457.2	6.3	0	20.7	53.975	108.0	46.86	12.70	500	410	102	87	39	814	806.8	510	395	325	255.3	20	2"

Dati non impegnativi - con riserva di apportare modifiche / These data are not legally binding. The Manufacturer reserves the right to modify its products without notice.

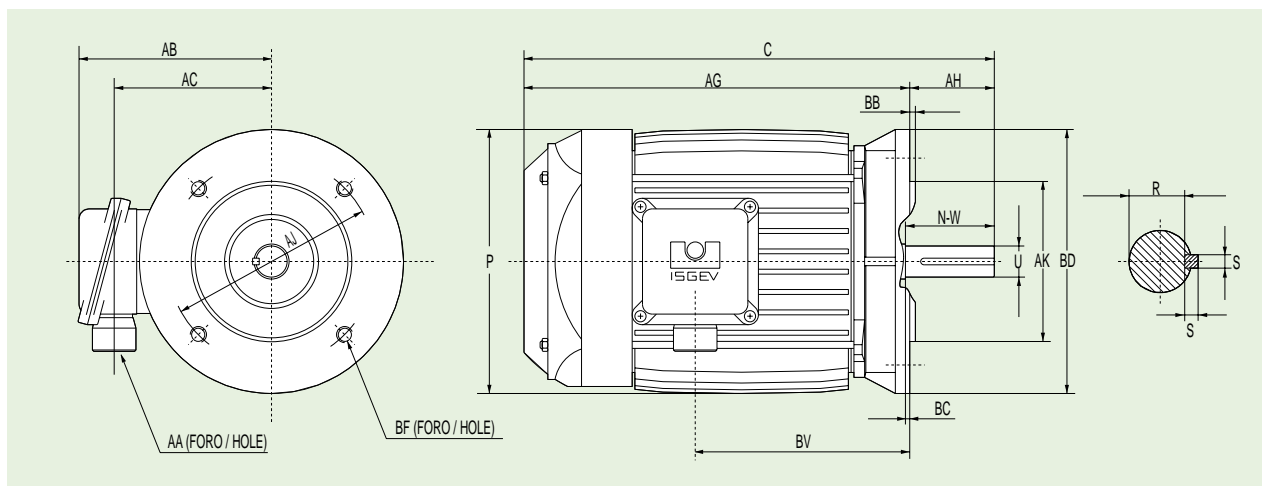

Tolleranza quota U: da 0 a -0.013  
 Tolleranza quota AK: da 0 a -0.076  
 Tolleranza quota BB: da 0 a -1.5

*U dimension tolerance: 0 to -0.013*  
*AK dimension tolerance: 0 to -0.076*  
*BB dimension tolerance: 0 to -1.5*

Forma costruttiva con flangia a fori filettati (NEMA C)  
 Construction form with flange with threaded holes (NEMA C)

Dimensioni in millimetri - *Dimensions in millimeters*

NEMA Frame Number	ISGEV Tipo Type	ACCOPPIAMENTO - SPORGENZA ALBERO COUPLING - SHAFT PROJECTION (NEMA)											INGOMBRO OVERALL DIMENSIONS							
		BD	AJ	AK	BB	BC	BF UNC	U	N-W	AH	R	S	C	AG	P	AB	AC	BV	AA NPT	
143 C	AS 90 S	165.1	149.22	114.3	4	3.2	3/8-16	22.225	57.2	54	19.58	4.77	307	253	189	140	112	126.9	1/2"	
145 C	AS 90 L	165.1	149.22	114.3	4	3.2	3/8-16	22.225	57.2	54	19.58	4.77	332	278	189	140	112	151.9	1/2"	
182 CH	AS 112 S																			
184 CH	AS 112 M	165.1	149.22	114.3	4	3.2	3/8-16	28.575	69.9	66.7	25.04	6.35	417	350.3	239	179	143	197	1/2"	

Dati non impegnativi - con riserva di apportare modifiche / *These data are not legally binding. The Manufacturer reserves the right to modify its products without notice.*

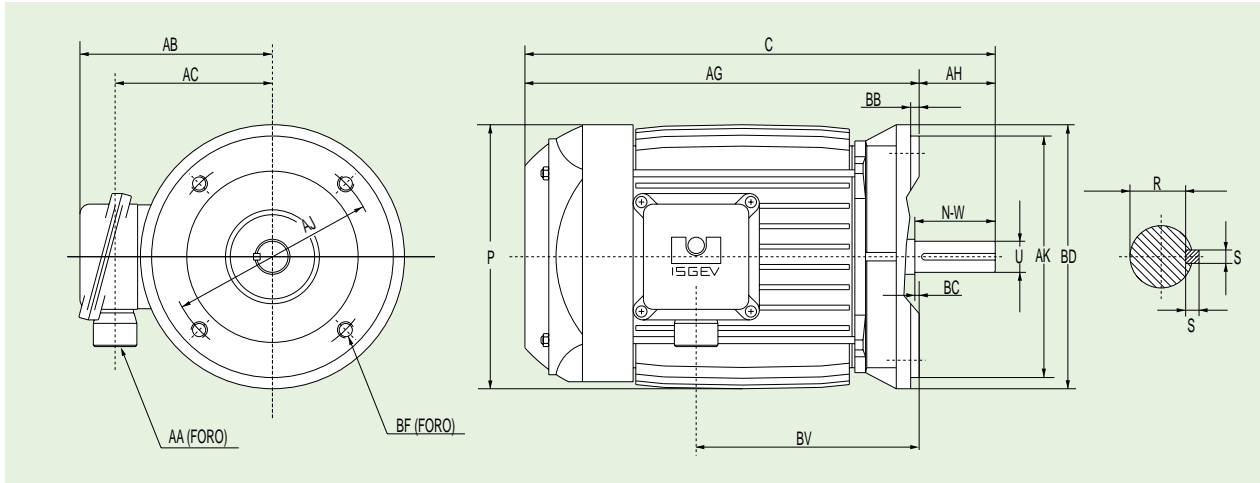

Tolleranze quota U: Fino al ø 34.925 da 0 a -0.013 , oltre, da 0 a -0.025  
 Tolleranze quota AK: Fino a frame 286C (AS 180L) da 0 a -0.076 , oltre, da 0 a -0.127  
 Da frame 213C (AS 132S) con golfare di sollevamento  
 Da frame 364C (AS 225S) flangia con 8 fori

*U dimension tolerance: up to 34.925 from 0 to -0.013, over, from 0 to -0.025  
 AK dimension tolerance: up to frame 286C (AS180L) from 0 to -0.076, over, from 0 to -0.127  
 From frame 213C (AS 132S) with lifting eyebolt  
 From 364C (AS 225S) flange with 8 holes*

Forma costruttiva con flangia a fori filettati (NEMA C)  
 Construction form with flange with threaded holes (NEMA C)

Dimensioni in millimetri - Dimensions in millimeters

NEMA Frame Number	ISGEV Tipo Type	ACCOPIAMENTO - SPORGENZA ALBERO COUPLING - SHAFT PROJECTION (NEMA)											INGOMBRO OVERALL DIMENSIONS						
		BD MAX	AJ	AK	BB MIN	BC	BF UNC	U	N-W	AH	R	S	C	AG	P	AB	AC	BV	AA NPT
182 C	AS 112 S	228.6	184.15	215.9	6.3	3.2	1/2"-13	28.575	69.9	66.7	25.04	6.35	417	350.3	239	179	143	197	1/2"
184 C	AS 112 M	228.6	184.15	215.9	6.3	3.2	1/2"-13	28.575	69.9	66.7	25.04	6.35	417	350.3	239	179	143	197	1/2"
213 C	AS 132 S	228.6	184.15	215.9	6.3	6.3	1/2"-13	34.925	85.7	79.4	30.50	7.92	454	374.6	268	204	162	197.3	3/4"
215 C	AS 132 M	228.6	184.15	215.9	6.3	6.3	1/2"-13	34.925	85.7	79.4	30.50	7.92	492	412.6	268	204	162	235.3	3/4"
254 C	AS 160 M	254.0	184.15	215.9	6.3	6.3	1/2"-13	41.275	101.6	95.3	35.96	9.52	579	483.7	324	245	194	267	1"
256 C	AS 160 L	254.0	184.15	215.9	6.3	6.3	1/2"-13	41.275	101.6	95.3	35.96	9.52	623	527.7	324	245	194	311	1"
284 C	AS 180 M	285.8	228.6	266.7	6.3	6.3	1/2"-13	47.625	117.5	111.2	40.41	12.70	671	559.8	365	265	214	322.8	1"
284 SC	AS 180 M	285.8	228.6	266.7	6.3	6.3	1/2"-13	41.275	82.6	76.3	35.96	9.52	636	559.8	365	265	214	322.8	1"
286 C	AS 180 L	285.8	228.6	266.7	6.3	6.3	1/2"-13	47.625	117.5	111.2	40.41	12.70	709	597.8	365	265	214	360.8	1"
286 SC	AS 180 L	285.8	228.6	266.7	6.3	6.3	1/2"-13	41.275	82.6	76.3	35.96	9.52	674	597.8	365	265	214	360.8	1"
324 C	AS 200 M	355.6	279.4	317.5	6.3	6.3	5/8"-11	53.975	133.4	127.1	46.86	12.70	787	659.9	407	317	254	395.8	1-1/2"
324 SC	AS 200 M	355.6	279.4	317.5	6.3	6.3	5/8"-11	47.625	95.3	89	40.41	12.70	749	659.9	407	317	254	395.8	1-1/2"
326 C	AS 200 L	355.6	279.4	317.5	6.3	6.3	5/8"-11	53.975	133.4	127.1	46.86	12.70	787	659.9	407	317	254	395.8	1-1/2"
326 SC	AS 200 L	355.6	279.4	317.5	6.3	6.3	5/8"-11	47.625	95.3	89	40.41	12.70	749	659.9	407	317	254	395.8	1-1/2"
364 C	AS 225 S	355.6	279.4	317.5	6.3	6.3	5/8"-11	60.325	149.2	142.9	51.33	15.87	838	695.1	447	392	288	404.6	2"
364 SC	AS 225 S	355.6	279.4	317.5	6.3	6.3	5/8"-11	47.625	95.3	89	40.41	12.70	784	695.1	447	392	288	404.6	2"
365 C	AS 225 M	355.6	279.4	317.5	6.3	6.3	5/8"-11	60.325	149.2	142.9	51.33	15.87	838	695.1	447	392	288	404.6	2"
365 SC	AS 225 M	355.6	279.4	317.5	6.3	6.3	5/8"-11	47.625	95.3	89	40.41	12.70	784	695.1	447	392	288	404.6	2"
404 C	BS 250 S	393.7	279.4	317.5	6.3	6.3	5/8"-11	73.025	184.2	177.9	62.23	19.05	991	806.8	510	395	325	255.3	2"
404 SC	BS 250 S	393.7	279.4	317.5	6.3	6.3	5/8"-11	53.975	108.0	101.7	46.86	12.70	914	806.8	510	395	325	255.3	2"
405 C	BS 250 M	393.7	279.4	317.5	6.3	6.3	5/8"-11	73.025	184.2	177.9	62.23	19.05	991	806.8	510	395	325	255.3	2"
405 SC	BS 250 M	393.7	279.4	317.5	6.3	6.3	5/8"-11	53.975	108.0	101.7	46.86	12.70	914	806.8	510	395	325	255.3	2"

Dati non impegnativi - con riserva di apportare modifiche / These data are not legally binding. The Manufacturer reserves the right to modify its products without notice.

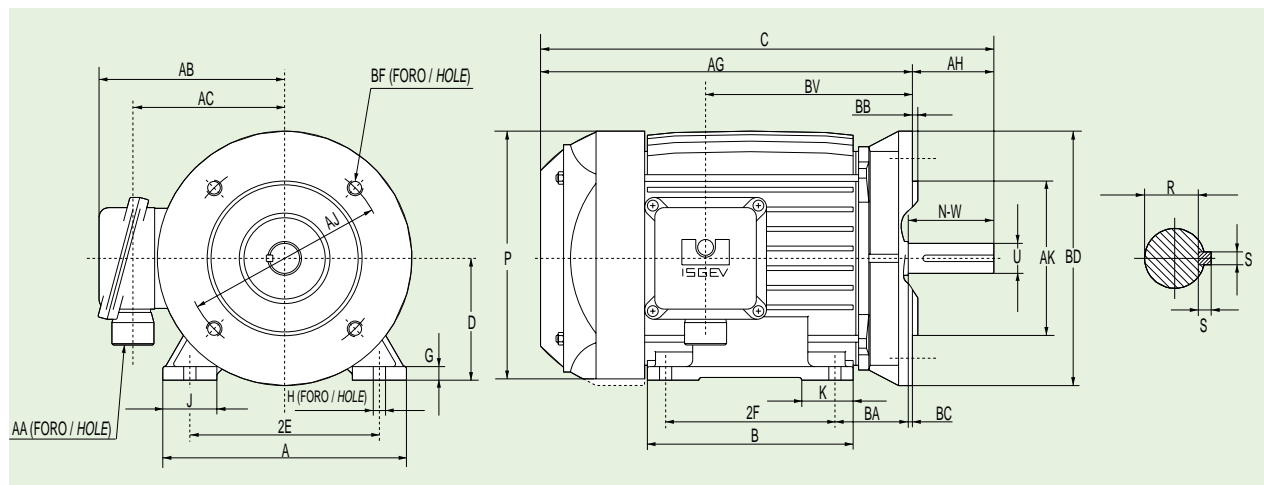

Tolleranza quota D: da 0 a -0.76  
 Tolleranza quota U: da 0 a -0.013  
 Tolleranza quota AK: da 0 a -0.076  
 Tolleranza quota BB: da 0 a -1.5

*D dimension tolerance: from 0 to - 0.76*  
*U dimension tolerance: from 0 to - 0.013*  
*AK dimension tolerance: from 0 to - 0.076*  
*BB dimension tolerance: from 0 to -1.5*

Forma costruttiva con piedini e flangia a fori filettati (NEMA TC)  
 Construction form with feet and flange with threaded holes (NEMA TC)

Dimensioni in millimetri - Dimensions in millimeters

NEMA Frame Number	ISGEV Tipo Type	ACCOPPIMENTO - SPORGENZA ALBERO COUPLING - SHAFT PROJECTION (NEMA)														INGOMBRO OVERALL DIMENSIONS													
		D	2E	2F	BA	H	BD	AJ	AK	BB	BC	BF UNC	U	N-W	AH	R	S	A	B	J	K	G	C	AG	P	AB	AC	BV	AA NPT
143 TC	AS 90 S	88.9	139.7	101.6	69.9	8.8	165.1	149.22	114.3	4	3.2	3/8-16	22.225	57.2	54	19.58	4.77	180	127	40	38	9	319	265	189	140	112	143.6	1/2"
145 TC	AS 90 L	88.9	139.7	127.0	69.9	8.8	165.1	149.22	114.3	4	3.2	3/8-16	22.225	57.2	54	19.58	4.77	180	152	40	38	9	344	290	189	140	112	168.6	1/2"
182 TCH	AS 112 S																												
184 TCH	AS 112 M	114.3	190.5	139.7	88.9	10.4	165.1	149.22	114.3	4	3.2	3/8-16	28.575	69.9	66.7	25.04	6.35	228	184	52	50	13	417	350.3	239	179	143	197	1/2"

Dati non impegnativi - con riserva di apportare modifiche / These data are not legally binding. The Manufacturer reserves the right to modify its products without notice.

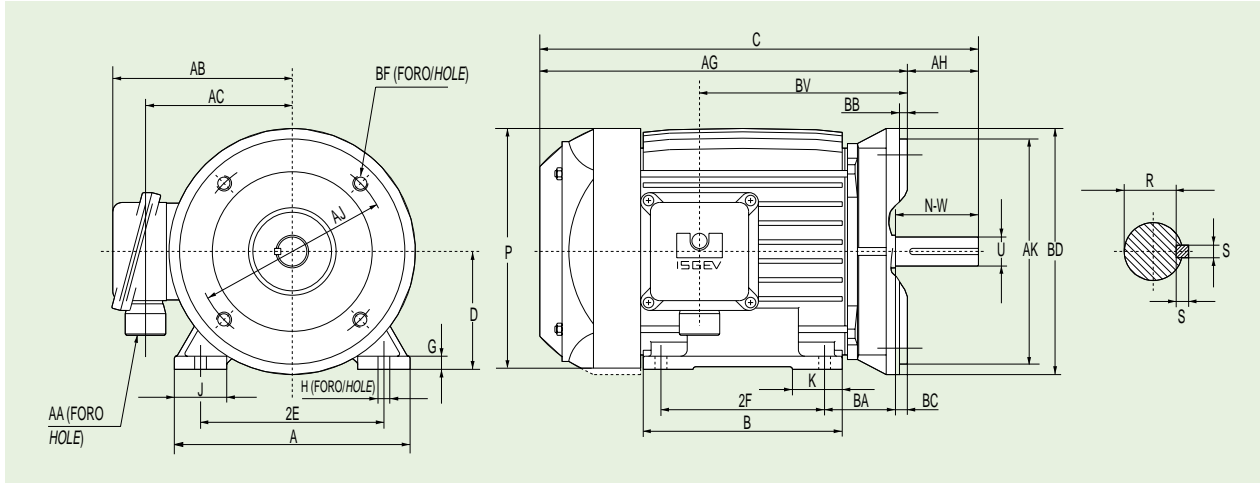

Tolleranza quota D: Da 0 a -0.76  
 Tolleranza quota U: Fino al ø 34.925 da 0 a -0.013 oltre, da 0 a -0.025  
 Da frame 213TC (AS 132S) con golfare di sollevamento  
 Tolleranza quota AK: Fino a frame 286TSC (AS 180L) da 0 a -0.076, oltre, da 0 a -0.127  
 Da frame 364TC (AS 225S) flangia con 8 fori

D dimension tolerance: 0 to -0.76  
 U dimension tolerance: up to ø 34.925 from 0 to -0.013, over, from 0 to -0.025  
 From frame 213C (AS 132) with lifting eyebolt  
 AK dimension tolerance: up to frame 286TSC (AS180L) from 0 to -0.076, over from 0 to -0.127  
 From 364TC (AS 225S) flange with 8 holes

Forma costruttiva con piedini e flangia a fori filettati (NEMA TC)  
 Construction form with feet and flange with threaded holes (NEMA TC)

**Dimensioni in millimetri - Dimensions in millimeters**

NEMA Frame Number	ISGEV Tipo Type	ACCOPPIAMENTO - SPORGENZA ALBERO (NEMA) COUPLING - SHAFT PROJECTION															INGOMBRO OVERALL DIMENSIONS												
		D	2E	2F	BA	H	BD max	AJ	AK	BB min	BC	BF UNC	U	N-W	AH	R	S	A	B	J	K	G	C	AG	P	AB	AC	BV	AA NPT
182 TC	AS 112 S																												
184 TC	AS 112 M	114.3	190.5	139.7	88.9	10.4	228.6	184.15	215.9	6.3	3.2	1/2-13	28.575	69.9	66.7	25.04	6.35	228	184	52	50	13	417	350.3	239	179	143	197	1/2"
213 TC	AS 132 S	133.4	215.9	139.7	108.0	10.4	228.6	184.15	215.9	6.3	6.3	1/2-13	34.925	85.7	79.4	30.50	7.92	260	198	60	58	14	473	393.6	268	204	162	216.3	3/4"
215 TC	AS 132 M	133.4	215.9	177.8	108.0	10.4	228.6	184.15	215.9	6.3	6.3	1/2-13	34.925	85.7	79.4	30.50	7.92	260	236	60	58	14	511	431.6	268	204	162	254.3	3/4"
254 TC	AS 160 M	158.8	254.0	209.6	120.7	13.5	254.0	184.15	215.9	6.3	6.3	1/2-13	41.275	101.6	95.3	35.96	9.52	310	272	65	70	17	601	505.7	324	245	194	289	1"
256 TC	AS 160 L	158.8	254.0	254.0	120.7	13.5	254.0	184.15	215.9	6.3	6.3	1/2-13	41.275	101.6	95.3	35.96	9.52	310	316	65	70	17	645	549.7	324	245	194	333	1"
284 TC	AS 180 M	177.8	279.4	241.3	120.7	13.5	285.8	228.6	266.7	6.3	6.3	1/2-13	47.625	117.5	111.2	40.41	12.70	350	308	70	75	22	671	559.8	365	265	214	322.8	1"
284TSC	AS 180 M	177.8	279.4	241.3	120.7	13.5	285.8	228.6	266.7	6.3	6.3	1/2-13	41.275	82.6	76.3	35.96	9.52	350	308	70	75	22	636	559.8	365	265	214	322.8	1"
286 TC	AS 180 L	177.8	279.4	279.4	120.7	13.5	285.8	228.6	266.7	6.3	6.3	1/2-13	47.625	117.5	111.2	40.41	12.70	350	346	70	75	22	709	597.8	365	265	214	360.8	1"
286TSC	AS 180 L	177.8	279.4	279.4	120.7	13.5	285.8	228.6	266.7	6.3	6.3	1/2-13	41.275	82.6	76.3	35.96	9.52	350	346	70	75	22	674	597.8	365	265	214	360.8	1"
324 TC	AS 200 M	203.2	317.5	266.7	133.4	16.7	355.6	279.4	317.5	6.3	6.3	5/8-11	53.975	133.4	127.1	46.86	12.70	396	370	78	85	31	787	659.9	407	317	254	395.8	1-1/2"
324TSC	AS 200 M	203.2	317.5	266.7	133.4	16.7	355.6	279.4	317.5	6.3	6.3	5/8-11	47.625	95.3	89	40.41	12.70	396	370	78	85	31	749	659.9	407	317	254	395.8	1-1/2"
326 TC	AS 200 L	203.2	317.5	304.8	133.4	16.7	355.6	279.4	317.5	6.3	6.3	5/8-11	53.975	133.4	127.1	46.86	12.70	396	370	78	85	31	787	659.9	407	317	254	395.8	1-1/2"
326TSC	AS 200 L	203.2	317.5	304.8	133.4	16.7	355.6	279.4	317.5	6.3	6.3	5/8-11	47.625	95.3	89	40.41	12.70	396	370	78	85	31	749	659.9	407	317	254	395.8	1-1/2"
364 TC	AS 225 S	228.6	355.6	285.8	149.3	16.7	355.6	279.4	317.5	6.3	6.3	5/8-11	60.325	149.2	142.9	51.33	15.87	440	380	85	95	35	838	695.1	447	392	288	404.6	2"
364TSC	AS 225 S	228.6	355.6	285.8	149.3	16.7	355.6	279.4	317.5	6.3	6.3	5/8-11	47.625	95.3	89	40.41	12.70	440	380	85	95	35	787	695.1	447	392	288	404.6	2"
365 TC	AS 225 M	228.6	355.6	311.2	149.3	16.7	355.6	279.4	317.5	6.3	6.3	5/8-11	60.325	149.2	142.9	51.33	15.87	440	380	85	95	35	838	695.1	447	392	288	404.6	2"
365TSC	AS 225 M	228.6	355.6	311.2	149.3	16.7	355.6	279.4	317.5	6.3	6.3	5/8-11	47.625	95.3	89	40.41	12.70	440	380	85	95	35	784	695.1	447	392	288	404.6	2"
404 TC	BS 250 S	254.0	406.4	311.2	168.3	20.7	393.7	279.4	317.5	6.3	6.3	5/8-11	73.025	184.2	177.9	62.23	19.05	500	410	102	87	39	991	813.1	510	395	325	261.6	2"
404TSC	BS 250 S	254.0	406.4	311.2	168.3	20.7	393.7	279.4	317.5	6.3	6.3	5/8-11	53.975	108.0	101.7	46.86	12.70	500	410	102	87	39	914	813.1	510	395	325	261.6	2"
405 TC	BS 250 M	254.0	406.4	349.3	168.3	20.7	393.7	279.4	317.5	6.3	6.3	5/8-11	73.025	184.2	177.9	62.23	19.05	500	410	102	87	39	991	813.1	510	395	325	261.6	2"
405TSC	BS 250 M	254.0	406.4	349.3	168.3	20.7	393.7	279.4	317.5	6.3	6.3	5/8-11	53.975	108.0	101.7	46.86	12.70	500	410	102	87	39	914	813.1	510	395	325	261.6	2"

Dati non impegnativi - con riserva di apportare modifiche / These data are not legally binding. The Manufacturer reserves the right to modify its products without notice.

**VERSIONE GHISA  
CAST IRON VERSION**



**MOTORI ASINCRONI TRIFASE  
3-PHASE INDUCTION MOTORS**



**MOTORI AUTOFRENANTI  
BRAKE MOTORS**



**MOTORI AUTOFRENANTI - Navale  
BRAKE MOTORS - Marine**



**MOTORI ANTIDEFLAGRANTI  
EXPLOSION PROOF MOTORS**



**MOTORI SERVOVENTILATI  
SERVO VENTILATED MOTORS**



**MOTORI TEMPERATURE ESTREME  
EXTREME TEMPERATUR MOTORS**



**MOTORI APPLICAZIONI FERROVIARIE  
RAILWAY MOTORS**



**MOTORE ALTA VELOCITÀ  
HIGH-SPEED MOTORS**



**MOTORI SINCRONI A RILUTTANZA  
SYNCHRONOUS RELUCTANCE  
MOTORS**



**UNITÀ DI STIRO PER FIBRE  
SINTETICHE  
STRETCHING UNITS**



**MOTORI FUSI MOTORIZZATI  
MOTORISED SPINDLE MOTORS**



**GRUPPI CONVERTITORE - CONVERTER UNITS  
REGOLATORE DI TENSIONE  
VOLTAGE REGULATORS**



**MOTORI VETTORIALI  
VECTOR MOTORS**



**MOTORI SOFT START  
SOFT START MOTORS**



**MOTORI CON INVERTER INTEGRATO  
MOTORS WITH INTEGRATED  
INVERTER**

**VERSIONE ALLUMINIO  
ALUMINIUM VERSION**



**MOTORI TRIFASE  
3-PHASE MOTORS**



**MOTORI MONOFASE  
SINGLE-PHASE MOTORS**



ISGEV s.p.a. 36071 ARZIGNANO (VI) ITALY  
Viale Vicenza, 62/bis  
Tel. ++39 0444 451928 r.a. Telefax ++39 0444 673402  
E-mail: info@isgev.com - Internet: www.isgev.com